



应用概述

无论是给电火花机、电线脱模器还是绕组的电动机线圈提供喂料，精密线张力是达到今天高性能标准的关键。精密线张力控制的关键是现场监测线张力。通过将测力单元与金属丝张紧装置相结合，可以开发出一种能适应电线质量和条件变化的多面线张力系统。此外，这种自适应系统可以保持高绕线质量和重复性，同时通过防止断线，可以最大限度地提高工艺效率。

使用产品

1 个在线拉压力测力传感器（LCM 系列），搭配 IAA 系列或 IDA100 放大器。

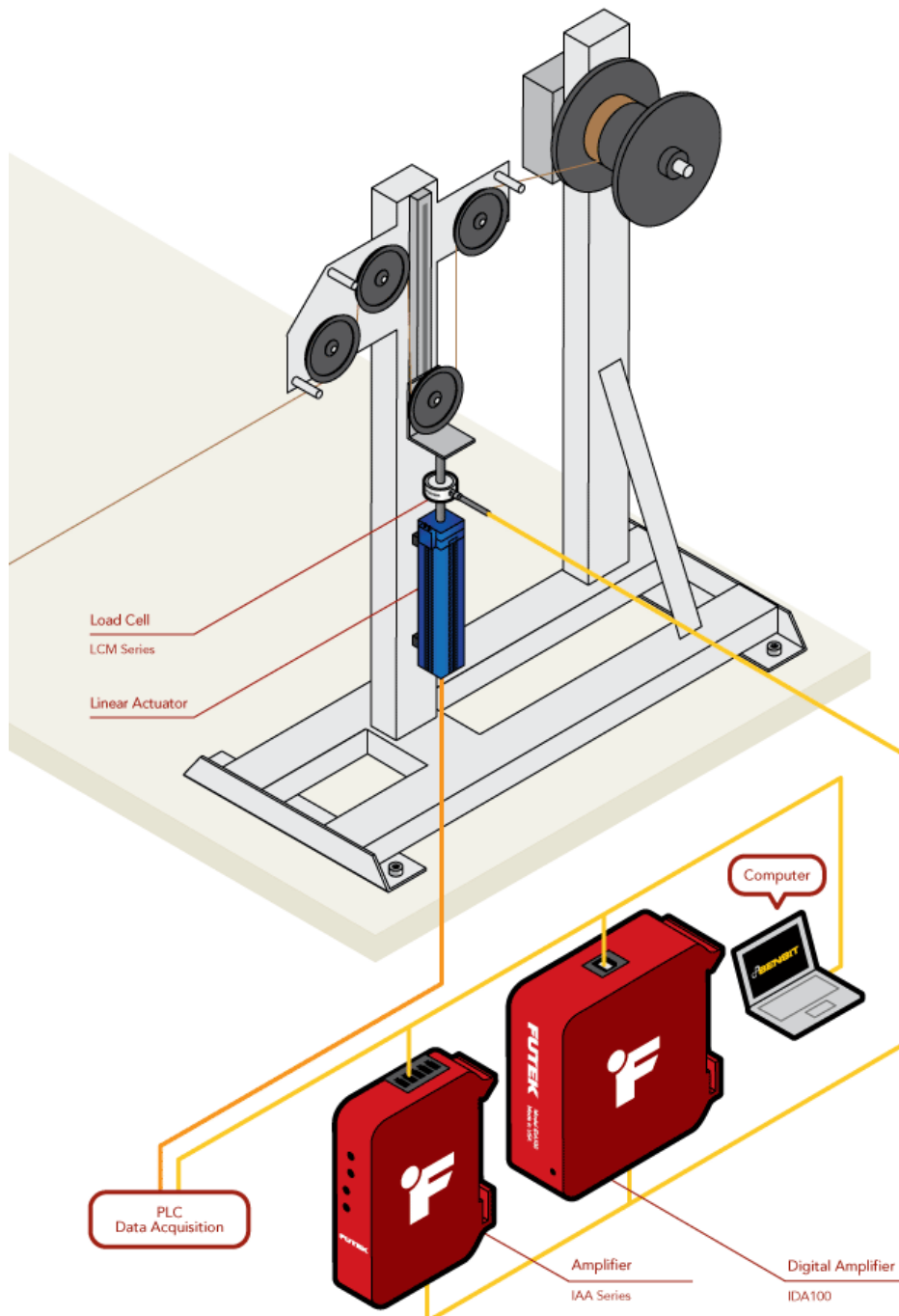

测力传感器

Sensor Solution Source

Load · Torque · Pressure · Multi Axis · Calibration · Instruments · Software

www.omgl.com.cn | sales@omgl.com.cn





使用说明

1. An LCM Series Miniature In Line Load Cell is mounted in-line between the wire tensioner and a linear actuator to measure wire tension
2. Adjusting the linear actuator piston causes changes in wire tension which generates a signal in the LCM series load cell
3. The signal from the LCM series load cell is then sent to the IAA series Analog Amplifier or IDA100 Digitally Configurable Amplifier
4. The amplified signal is then fed into a PLC/Motion Controller which drives the liner actuator, closing the control loop, and allowing the system to actively adapt to changing wire conditions
5. With the IDA100, amplifier output can be simultaneously monitored and adjusted on a Windows PC with FUTEK's SENSIT™ software while providing high speed, amplified, analog output.

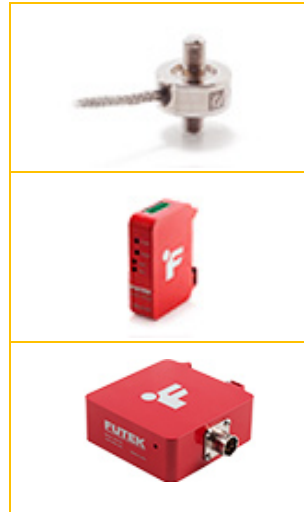

ICM 系列

微型轴向拉压力传感器

IAA 系列

应变式放大器

IDA100

可配置数字放大器