

PROPRIETARY AND CONFIDENTIAL

THE INFORMATION CONTAINED IN THIS DRAWING IS THE SOLE PROPERTY OF DYTRAN INSTRUMENTS INC. ANY REPRODUCTION IN PART OR AS A WHOLE WITHOUT THE WRITTEN PERMISSION OF DYTRAN INSTRUMENTS INC. IS PROHIBITED

MODEL	SENSITIVITY
3056D1T	10 mV/g
3056D2T	100 mV/g
3056D3T	500 mV/g
3056D4T	20 mV/g
3056D5T	50 mV/g
3056D6T	200 mV/g
3056D7T	1 mV/g
3056D8T	5 mV/g

REVISIONS

REV.	ECN	DESCRIPTION	BY/DATE	CHK	APPR
A	11394	INITIAL RELEASE	RA 11/06/14	EM	DV
B	11983	ADDED 3056D7T & D8T	LA 05/18/15	RT	DV
C	12426	ADDED VIEW A-A, REMOVED ISOMETRIC VIEW	RA, 01/06/16	EM	LN
D	14310	ZONE B3 10-32 UNF WAS: 1032 UNC	RA, 07/10/18	W	MH

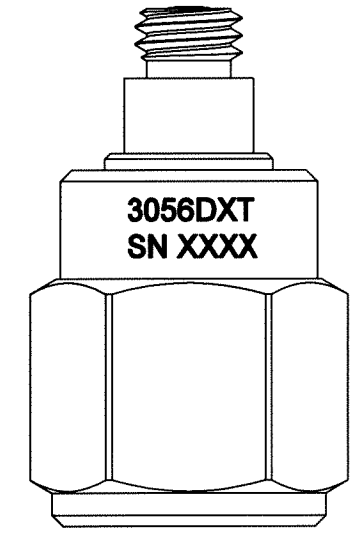
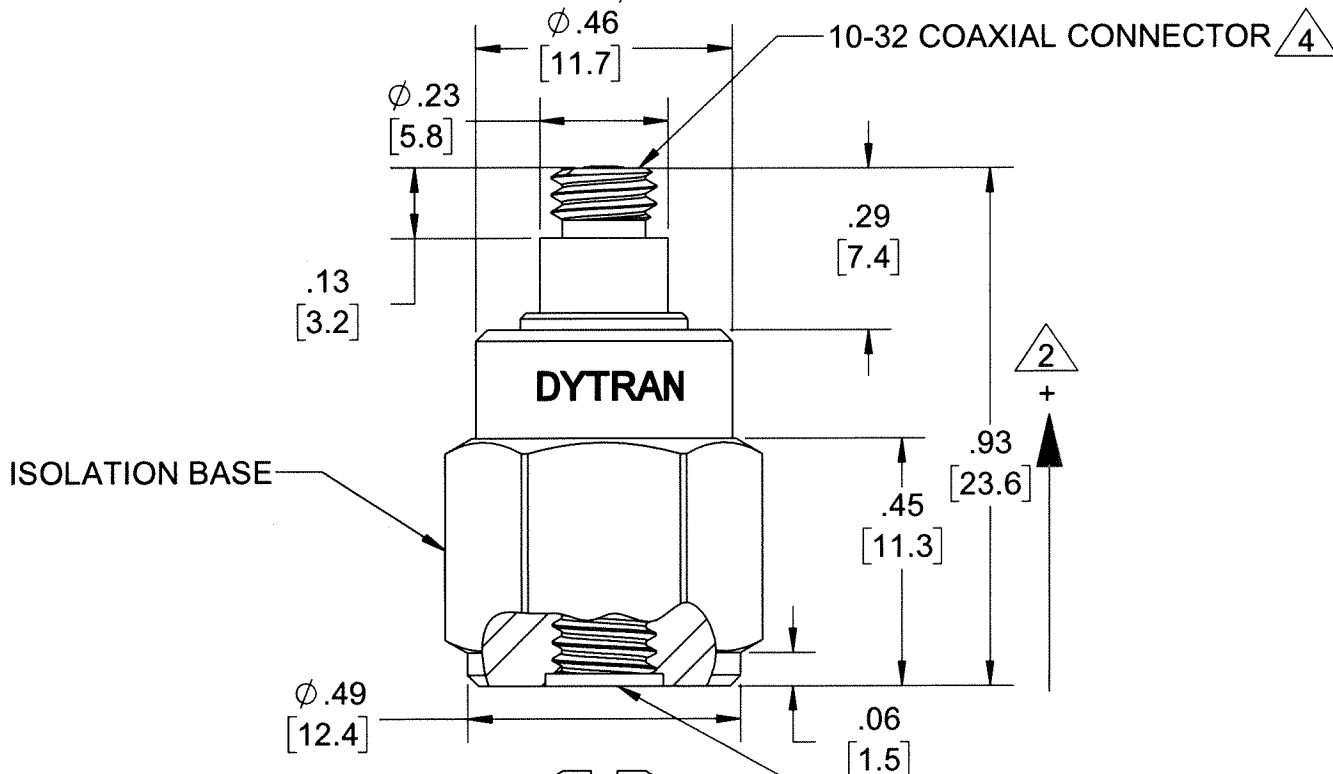
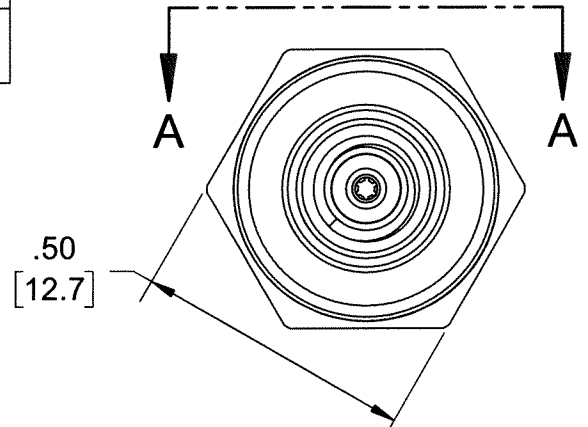

VIEW A-A  
ROTATED 180°

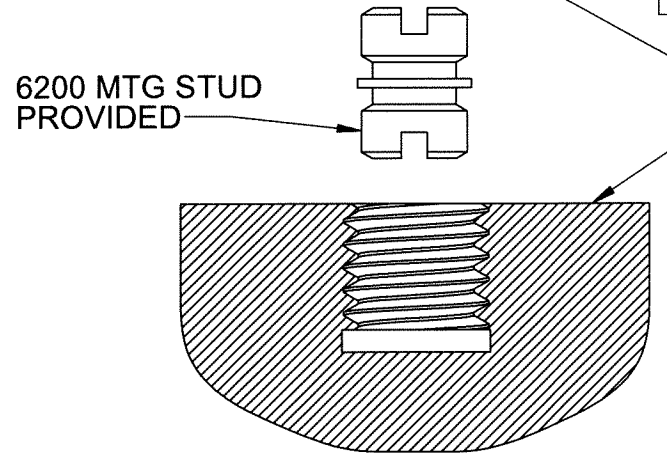

**MOUNTING SURFACE HOLE PREPARATION:**  
SELECT SURFACE FLAT TO .001 TIR  
TAP 10-32 UNF-2B X .200 MIN THD DEPTH

- 4 MATES WITH DYTRAN 6010AXX OR 6011AXX CABLE (XX=LENGTH IS FEET)
  - 3. WEIGHT: 10 GRAMS (APPROX)
  - 2 ARROW INDICATES ACCELERATION DIRECTION FOR POSITIVE OUTPUT.
  - 1. MATERIAL: TITANIUM ALLOY
- NOTES: UNLESS OTHERWISE SPECIFIED

UNLESS OTHERWISE SPECIFIED: INTERPRET DIM & TOL PER ASME Y14.5M - 1994. REMOVE BURRS. COUNTERSINK INTERNAL THDS 90° TO MAJOR DIA. CHAM EXT THDS 45° TO MINOR DIA. THD LENGTHS AND DEPTHS ARE FOR MIN FULL THDS. DIMENSIONS APPLY AFTER FINISHING.	UNLESS OTHERWISE SPECIFIED: DIMENSIONS ARE IN INCHES. TOLERANCES ARE:		
	DECIMALS .XX ±.03 .XXX ±.010	METRIC X ± 0.8 .XX ±0.25	ANGLES ±1°
	APPROVALS	DATE	
	ORIG RA	10/29/14	
CHK EM	12/12/14		
APP DV	12/17/14		
DO NOT SCALE DRAWING	THIRD ANGLE PROJECTION		

**DYTRAN INSTRUMENTS, INC.** Chatsworth, CA

**MASTER ONLY IF IN RED**

TITLE: **OUTLINE/INSTALLATION, MODEL 3056DXT**

SIZE B	CAGE CODE 2W033	DWG NO 127-3056DT	REV D
SCALE: 3:1	PART NO:	SHEET 1 OF 1	



- HERMETICALLY SEALED
- BASE ISOLATED
- TEDS

**PHYSICAL**

Weight  
Connector Type  
Mounting Provision  
Material, Housing/Connector  
Sensing Element  
Element Style

ENGLISH		SI	
0.35	oz	10	grams
10-32		10-32	
10-32 X .150 ↓		10-32 X .150 ↓	
Titanium		Titanium	
Ceramic		Ceramic	
Planar Shear		Planar Shear	

**PERFORMANCE**

Sensitivity, ±5% [1]  
Range for ± 5 Volts Output  
Frequency Response, ±10%  
Resonant Frequency  
Broad Band Resolution  
Linearity [2]  
Maximum Transverse Sensitivity  
Strain Sensitivity @ 250µε

5	mV/G	0.5	mV/m/s <sup>2</sup>
1,000	G peak	9810	m/s <sup>2</sup>
1 to 10,000	Hz	1 to 10,000	Hz
> 36	kHz	> 36	kHz
0.008	G rms	0.08	m/s <sup>2</sup> rms
±1	% F.S.	±1	% F.S.
5	%	5	%
0.001	G/µε	0.01	m/s <sup>2</sup> /µε

**ENVIRONMENTAL**

Maximum Vibration  
Maximum Shock  
Operating Temperature Range  
TEDS Operating Temperature  
Seal

800	G peak	7848	m/s <sup>2</sup> peak
5000	G peak	49050	m/s <sup>2</sup> peak
-60 to +250	°F	-51 to 121	°C
-40 to +185	°F	-40 to +85	°C
HERMETIC		HERMETIC	

**ELECTRICAL**

Supply Current Range [3]  
Compliance Voltage Range  
Output Impedance, Typ  
Bias Voltage  
Discharge Time Constant  
Electrical Isolation  
TEDS

2 to 20	mA	2 to 20	mA
+18 to +30	Volts	+18 to +30	Volts
100	Ω	100	Ω
+9 to +13	VDC	+9 to +13	VDC
.5 to 1.5	Sec	.5 to 1.5	Sec
10	GΩ,min	10	GΩ,min
IEEE 1451.4		IEEE 1451.4	

**This family also includes:**

Model	Sensitivity (mV/g)	Frequency Response (Hz)	Time Constant (Sec)	Operating Temp (°F)
3056D1T	10	1 to 10000	0.5 to 1.5	-60 to +250
3056D2T	100	1 to 10000	0.5 to 1.5	-60 to +250
3056D3T	500	1 to 10000	0.5 to 1.5	-60 to +225
3056D4T	20	1 to 10000	0.5 to 1.5	-60 to +250
3056D5T	50	1 to 10000	0.5 to 1.5	-60 to +250
3056D6T	200	1 to 10000	0.5 to 1.5	-60 to +225
3056D7T	1	1 to 10000	0.5 to 1.5	-60 to +250

Refer to the performance specifications of the products in this family for detailed description

**Supplied Accessories:**

- 1) Accredited calibration certificate (ISO 17025)
- 2) Model 6200 mounting stud, QTY 1

**Notes:**

- [1] Measured at 100Hz, 1 Grms per ISA RP 37.2.
- [2] Measured using zero-based straight line method, % of F.S. or any lesser range.
- [3] Do not apply power to this system without current limiting, 20 mA MAX. To do so will destroy the IC charge amplifier.
- [4] In the interest of constant product improvement, we reserve the right to change specifications without notice.

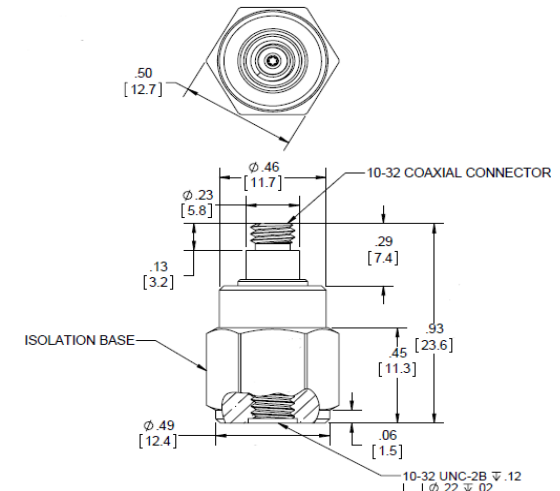
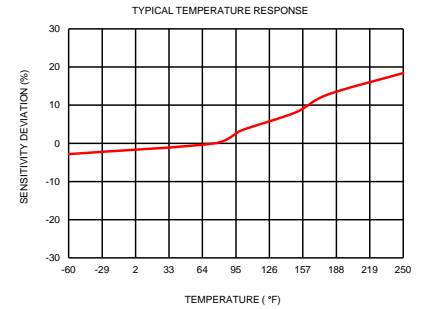
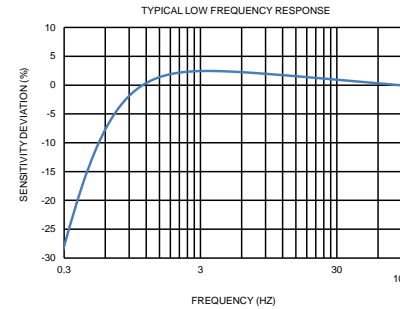

Units on the line drawing are in inches, units in brackets are in millimeters. Refer to 127-3056DT for more information.

