

PROPRIETARY AND CONFIDENTIAL

THE INFORMATION CONTAINED IN THIS DRAWING IS THE SOLE PROPERTY OF DYTRAN INSTRUMENTS INC. ANY REPRODUCTION IN PART OR AS A WHOLE WITHOUT THE WRITTEN PERMISSION OF DYTRAN INSTRUMENTS INC. IS PROHIBITED

REVISIONS

REV	ECN	DESCRIPTION	BY/DATE	CHK	APPR
A	9795	INITIAL RELEASE	AB 04/01/13	RA	DV
B	10997	SCREW LENGTH (.79 [20]) WAS .39 [10]	EC 05/13/14	JLS	

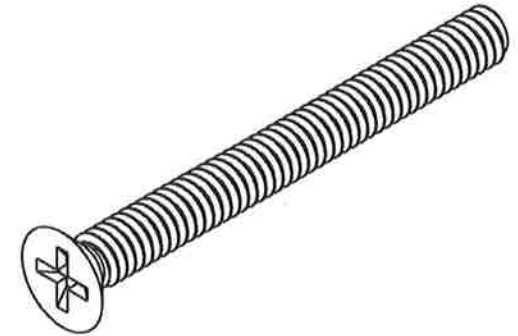
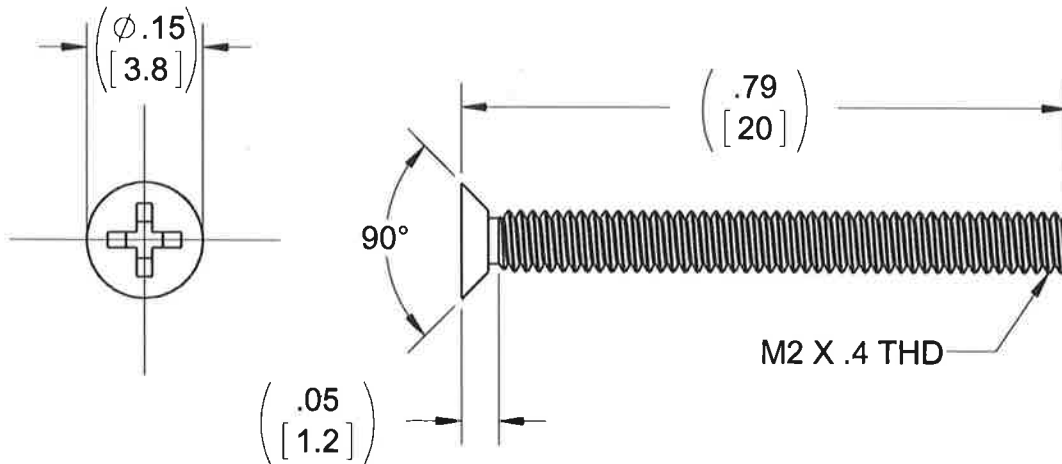

USED ON	NEXT ASSY
APPLICATION	
THIRD ANGLE PROJECTION USA	

UNLESS OTHERWISE SPECIFIED:
 INTERPRET DIM & TOL PER ASME Y14.5M - 1994.
 REMOVE BURRS.
 COUNTERSINK INTERNAL THDS 90° TO MAJOR DIA.
 CHAM EXT THDS 45° TO MINOR DIA.
 THD LENGTHS AND DEPTHS ARE FOR MIN FULL THDS.
 THDS PER MIL-S-7742.
 DIMENSIONS APPLY AFTER FINISHING.

ALL MACHINED SURFACES. TOTAL RUNOUT WITHIN .005.
 BREAK SHARP EDGES .005 TO .010.
 MACHINED FILLET RADII .005 TO .015.
 WELDING SYMBOLS PER AWS A2.4.
 ABBREVIATIONS PER MIL-STD-12.

UNLESS OTHERWISE SPECIFIED:
 DIMENSIONS ARE IN INCHES. DIMENSIONS IN BRACKETS [] ARE IN MILLIMETERS
 TOLERANCES ARE:

INCHES	METRIC	ANGLES
.XX ± .03	.X ± 0.8	± 1°
.XXX ± 0.10	.XX ± 0.25	

MATERIAL
18-8 STAINLESS STEEL

FINISH

DO NOT SCALE DRAWING

CONTRACT NO.

APPROVALS		DATE
ORIG	AB	04/01/13
CHK	RA	04/18/13
APP	DV	05/08/13
APP		

DYTRAN INSTRUMENTS, INC. Chatsworth, CA

MASTER ONLY IF IN RED

TITLE:
MOUNTING SCREW, M2X.4 X 20MM

SIZE	CAGE CODE	DWG. NO.	REV
A	2W033	127-6914	B

SCALE: NONE SOLIDWORKS SHEET 1 OF 1